

# Capillary Clip

Tubing / Cable

## DESCRIPTION & FEATURES

The Klipet Model CC-1 is a capillary clip and sensor holder made of sturdy plenum-rated nylon. It is available in black, gray or natural with the Klipet logo; custom colors and logos also available.

- ▶ Hold three different sizes of capillary tubing: 1/8", 1/4" or 3/8"
- ▶ Slots for tie anchors
- ▶ Inside tapered ridges allow tubing to be snapped in place
- ▶ Mounting in either horizontal or vertical planes
- ▶ Corner slot accepts 1/4" sensors
- ▶ Clips can be separated into two parts:
  - Use one as a capillary mounting clip
  - The other part can be used as a sensor mounting bracket
- ▶ Plenum rated, class 94V-2 nylon
- ▶ Available in NATURAL, GREY & BLACK



## DIMENSIONS

Overall: 2"W x 1/2"D  
 Capillary Tube Openings: 1/8", 1/4" & 3/8"  
 Sensor / Tube Opening: 1/4"

## ORDERING INFO

**PART NUMBER**

CC1-N.....	NATURAL
CC1-G.....	GREY
CC1-BK.....	BLACK
CC1-B.....	BEIGE
CC1-B-NL.....	BEIGE, no Logo
CC1-W-NL.....	WHITE, no Logo

Custom colors and logos available (10,000 piece minimum)

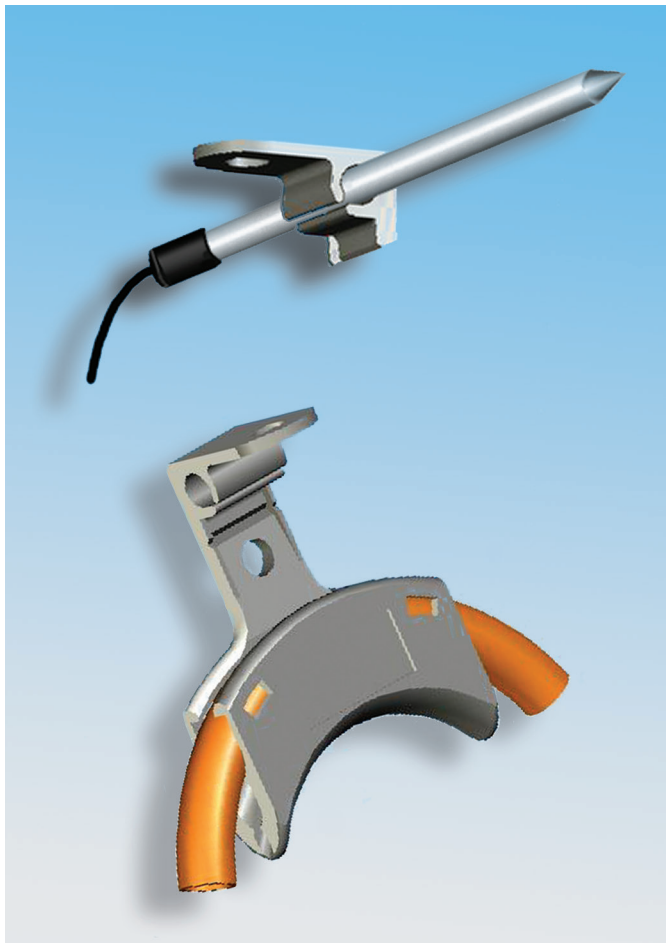

**STURDY DESIGN  
 REPLACES  
 OLD COPPER  
 "ONE SIZE ONLY" CLIPS**



# Capillary Clip

Tubing / Cable



## DESIGN ENHANCEMENTS

Clip can be separated into two parts at the notch

- Use one as a capillary mounting clip
- The other part can be used as a sensor mounting bracket

Corner slot accepts 1/4" TUBE or SENSOR

90° mounting in either horizontal or vertical planes

Openings for capillary tubing - three sizes:

3/8"

1/4"

1/8"

Slots for tie anchors, use if needed.

Note: Inside tapered ridges allow tubing to be snapped in and held in place without the use of tie wraps.

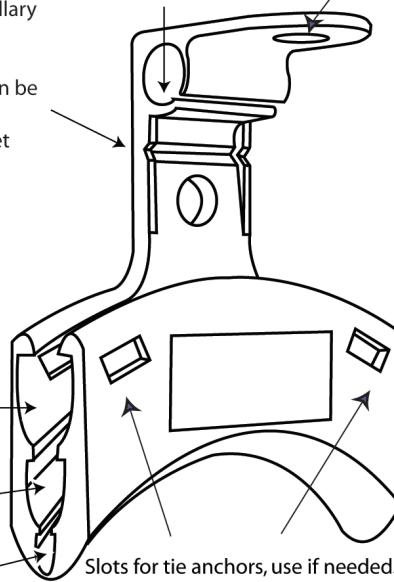

## DIMENSIONS

